



# INSTALLATION INSTRUCTIONS

Accessory  
**CROSS BARS**  
P/N 08L04-TZ5-200

Application  
**2016 MDX**

Publications No.  
**VERSION 1**  
Issue Date  
**JAN 2015**

## PARTS LIST

Front cross bar (long)

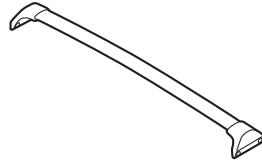

Rear cross bar (short)

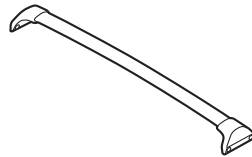

8 Bolts

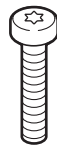

## TOOLS AND SUPPLIES REQUIRED

- Ratchet
- Torque wrench
- T-30 TORX bit

## INSTALLATION

### NOTE:

- The weight of the cargo must not exceed the maximum weight capacity of 75 kg (165 lbs).
- Be extremely careful not to damage the roof and other finished surfaces of the body when installing the cross bars.

- Remove four plastic screws from the left roof rail and four plastic screws from the right roof rail.

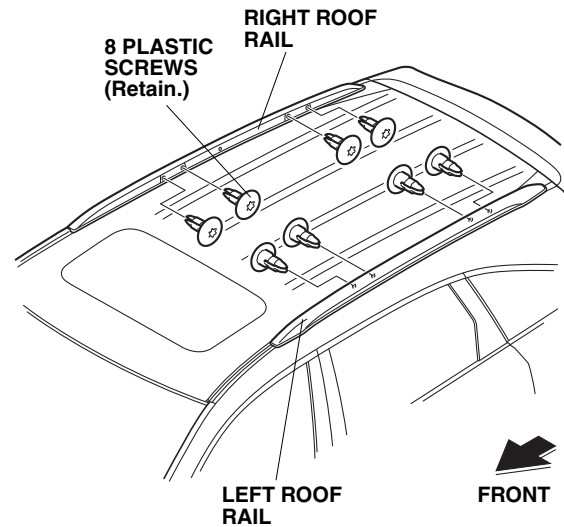

QBN1101AH

- Install the front cross bar to the left roof rail and right roof rail with four bolts. Torque the bolts to 10 N·m (7.4 lbf·ft).

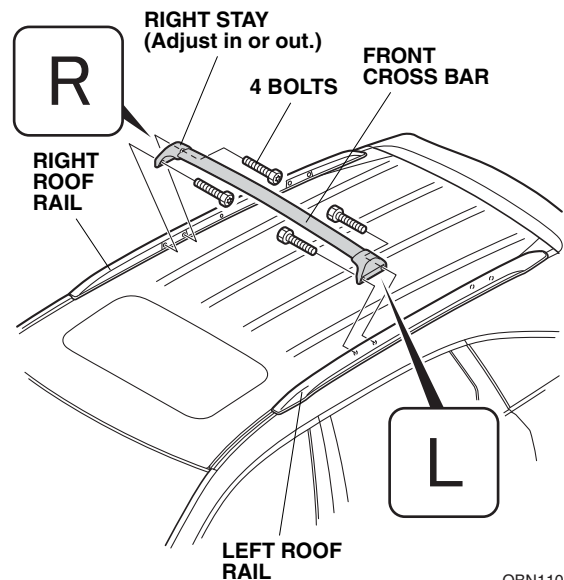

QBN1102AH

3. Install the rear cross bar to the left roof rail and right roof rail with four bolts. Torque the bolts to 10 N·m (7.4 lbf·ft).

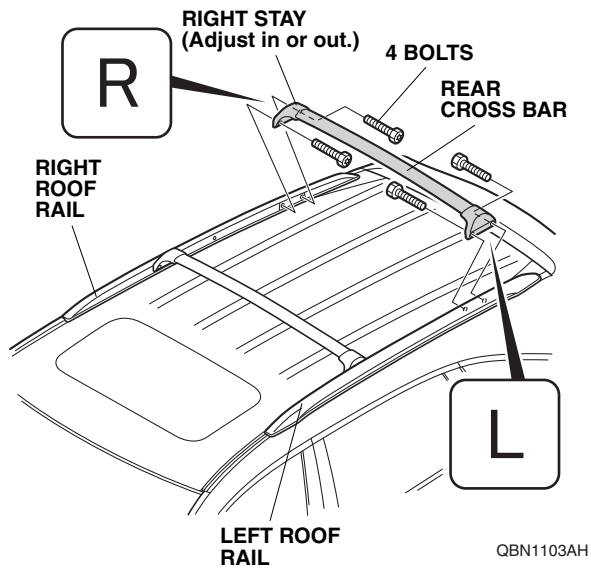

#### USE AND CARE

- Check the roof rail mounting bolts frequently, and retighten if necessary.
- Distribute the weight of the cargo evenly, and do not exceed the maximum weight capacity of 75 kg (165 lbs).